



GPS 35 LP TracPak™

GPS SMART ANTENNA

TECHNICAL SPECIFICATION

Models:

GPS35-LVC

GPS35-LVS

GPS35-HVS

© 1998 GARMIN Corporation, 1200 E. 151st Street, Olathe, KS 66062

All rights reserved. No part of this manual may be reproduced or transmitted in any form or by any means, electronic or mechanical, including photocopying and recording, for any purpose without the express written permission of GARMIN.

Information in this document is subject to change without notice. GARMIN reserves the right to change or improve their products and to make changes in the content without obligation to notify any person or organization of such changes or improvements.

December, 1998

190-00148-00 Rev. D

CAUTION

The GPS system is operated by the government of the United States which is solely responsible for its accuracy and maintenance. Although the GPS 35LP is a precision electronic NAVigation AID (NAVAID), any NAVAID can be misused or misinterpreted, and therefore become unsafe. Use the GPS 35LP at your own risk. To reduce the risk, carefully review and understand all aspects of this Technical Manual before using the GPS 35LP. When in actual use, carefully compare indications from the GPS 35LP to all available navigation sources including the information from other NAVAIDs, visual sightings, charts, etc. For safety, always resolve any discrepancies before continuing navigation.

NOTE

This device has been tested and found to comply with the limits for a Class B digital device, pursuant to Part 15 of the FCC Rules. Operation is subject to the following two conditions: (1) This device may not cause harmful interference, and (2) this device must accept any interference received, including interference that may cause undesired operation.

This device generates, uses and can radiate radio frequency energy and, if not installed and used in accordance with the instructions, may cause harmful interference to radio communications. However, there is no guarantee that interference will not occur in a particular installation. If this device does cause harmful interference to radio or television reception, which can be determined by turning the device off and on, you are encouraged to try to correct the interference by one or more of the following measures:

- Reorient or relocate the receiving antenna.
- Increase the separation between this device and the receiver.
- Connect this device to an outlet on a different circuit than that to which the receiver is connected.
- Consult the dealer or an experienced radio/TV technician for help.

This device contains no user-serviceable parts. Repairs should only be performed by an authorized GARMIN service center. Unauthorized repairs or modifications to this device could void your warranty and your authority to operate this device under Part 15 regulations.

TABLE OF CONTENTS

1.	Introduction	1
	1.1 Overview	1
	1.2 Features	1
	1.3 Naming Conventions	2
	1.4 Technical Specifications	2
	1.5 Application	4
2.	Operational Characteristics	5
	2.1 Self Test	5
	2.2 Initialization	5
	2.3 Navigation	6
	2.4 Satellite Data Collection	6
3.	Hardware Interface	8
	3.1 Mechanical Dimensions	8
	3.2 Mounting Configurations and Options	9
	3.3 Connection Wiring Description	13
4.	Software Interface	14
	4.1 NMEA Received Sentences	14
	4.2 NMEA Transmitted Sentences	17
	4.3 Baud Rate Selection	21
	4.4 One-Pulse-Per-Second Output	22
	4.5 RTCM Received Data	22
A.	Earth Datums	23
B.	GPS 35LP Evaluation Kits	26
C.	Phase Data Output	28

SECTION 1

INTRODUCTION

1.1 OVERVIEW

The GARMIN GPS 35LP is a complete GPS receiver, including an embedded antenna, designed for a broad spectrum of OEM (Original Equipment Manufacturer) system applications. Based on the proven technology found in other GARMIN 12 channel GPS receivers, the GPS 35LP will track up to 12 satellites at a time while providing fast time-to-first-fix, one second navigation updates and low power consumption. Its far reaching capability meets the sensitivity requirements of land navigation as well as the dynamics requirements of high performance aircraft.

The GPS 35LP design utilizes the latest technology and high level circuit integration to achieve superior performance while minimizing space and power requirements. All critical components of the system including the RF/IF receiver hardware and the digital baseband are designed and manufactured by GARMIN to ensure the quality and capability of the GPS 35LP. This hardware capability combined with software intelligence makes the GPS 35LP easy to integrate and use.

The GPS 35LP is designed to withstand rugged operating conditions and is completely water resistant. The GPS 35LP is a complete GPS receiver that requires minimal additional components be supplied by an OEM or system integrator. A minimum system must provide the GPS 35LP with a source of power and a clear view of the GPS satellites. The system may communicate with the GPS 35LP via a choice of two RS-232 compatible full duplex communication channels (-xVS series), or two full duplex CMOS channels (-xVC series). Internal memory backup allows the GPS 35LP to retain critical data such as satellite orbital parameters, last position, date and time. End user interfaces such as keyboards and displays are added by the application designer.

1.2 FEATURES

The GPS 35LP provides a host of features that make it easy to integrate and use.

- 1) Full navigation accuracy provided by Standard Positioning Service (SPS)
- 2) Compact design ideal for applications with minimal space
- 3) High performance receiver tracks up to 12 satellites while providing fast first fix and low power consumption
- 4) Differential capability utilizes real-time RTCM corrections producing 3-10 meter position accuracy
- 5) Internal clock and memory are sustained by a rechargeable memory backup battery. The battery recharges during normal operation.
- 6) User initialization is not required
- 7) Navigation mode (2D or 3D) may be configured by the user
- 8) Two communication channels and user selectable baud rates allow maximum interface capability and flexibility

- 9) Highly accurate one-pulse-per-second output for precise timing measurements. Pulse width is configurable in 20 msec increments from 20 msec to 980 msec.
- 10) Binary Format Phase Data Output on TXD2
- 11) Flexible input voltage levels of 3.6Vdc to 6.0Vdc with overvoltage protection in the -LVx versions, and 6.0Vdc to 40Vdc in the -HVx versions.
- 12) FLASH based program memory. New software revisions upgradeable through serial interface.

1.3 Naming Conventions

The GPS 35LP Series TrackPack™ receivers are delineated with a three letter extension to designate the operating voltage range and the serial data voltage specification.

High Voltage - GPS35-HVx designation indicates that the unit will accept a high input voltage. The internal switching regulator will operate from a 6VDC to 40VDC unregulated supply.

Low Voltage - GPS35-LVx designation indicates that the unit is designed to operated from a low voltage 3.6VDC to 6.0VDC supply. Operation at about 4VDC is the most power efficient mode of operation for the GPS35LP receiver. The unit is protected if a high voltage is inadvertently applied to the input.

RS-232 Serial Data - GPS35-xVS designation means that the two bi-directional serial data ports are true RS-232 ports conforming to the RS-232E standard.

CMOS Serial Data - GPS35-xVC designation means that the two bi-directional serial data ports use CMOS output buffers. The input buffers will accept either CMOS(TTL) voltage levels or RS-232 voltage levels. This configuration is adequate for communicating directly with serial devices over short cable lengths (less than 20 meters).

1.4 TECHNICAL SPECIFICATIONS

Specifications are subject to change without notice.

1.4.1 Physical Characteristics

- 1) Single construction integrated antenna/receiver.
- 2) Weight: 4.4 oz, (124.5 g), not including cable
- 3) Size: 2.230" (w) x 3.796" (l) x 1.047" (h), (56.64 mm x 96.42 mm x 26.60 mm)

1.4.2 Environmental Characteristics

- 1) Operating temperature: -30°C to +85°C (internal temperature)
- 2) Storage temperature: -40°C to +90°C

1.4.3 Electrical Characteristics

- 1) Input voltage: +3.6VDC to 6.0VDC regulated, 150mV ripple -LVx versions.
+6.0VDC to 40VDC unregulated -HVx version.
- 2) Input current: 120 mA typical 140 mA max -LVx versions, 20 mA while in power down.
870mW typical 1000mW max -HVx version, 300uA while in power down.
- 3) Backup power: 3V Rechargeable Lithium cell battery, up to 6 month charge.
- 4) Power Down Input: 2.7V threshold

1.4.4 Performance

- 1) Tracks up to 12 satellites (up to 11 with PPS active)
- 2) Update rate: 1 second
- 3) Acquisition time
 - 15 seconds warm (all data known)
 - 45 seconds cold (initial position, time and almanac known, ephemeris unknown)
 - 5.0 minutes AutoLocate™ (almanac known, initial position and time unknown)
 - 5 minutes search the sky (no data known)
- 4) Position accuracy:
Differential GPS (DGPS): 5 meters RMS
Non-differential GPS: 15 meters RMS (100 meters with Selective Availability on)
- 5) Velocity accuracy: 0.2 m/s RMS steady state (subject to Selective Availability)
- 6) Dynamics: 999 knots velocity, 6g dynamics
- 7) One-pulse-per-second accuracy: +/-1 microsecond at rising edge of PPS pulse (subject to Selective Availability)

1.4.5 Interfaces

- 1) Dual channel CMOS/TTL level (-xVC versions) or RS-232 compatible level (-xVS versions), with user selectable baud rate (300, 600, 1200, 2400, 4800, 9600, 19200)
- 2) NMEA 0183 Version 2.0 ASCII output (GPALM, GPGGA, GPGSA, GPGSV, GPRMC, GPVTG, PGRME, PGRMT, PGRMV, PGRMF, LCGLL, LCVTG)

Inputs

- Initial position, date and time (not required)
- Earth datum and differential mode configuration command, PPS Enable, almanac

Outputs

- Position, velocity and time

- Receiver and satellite status
 - Differential Reference Station ID and RTCM Data age
 - Geometry and error estimates
- 3) Real-time Differential Correction input (RTCM SC-104 message types 1,2,3 and 9)
 - 4) One-pulse-per-second timing output
 - 5) Binary Format Phase Data

1.5 APPLICATION

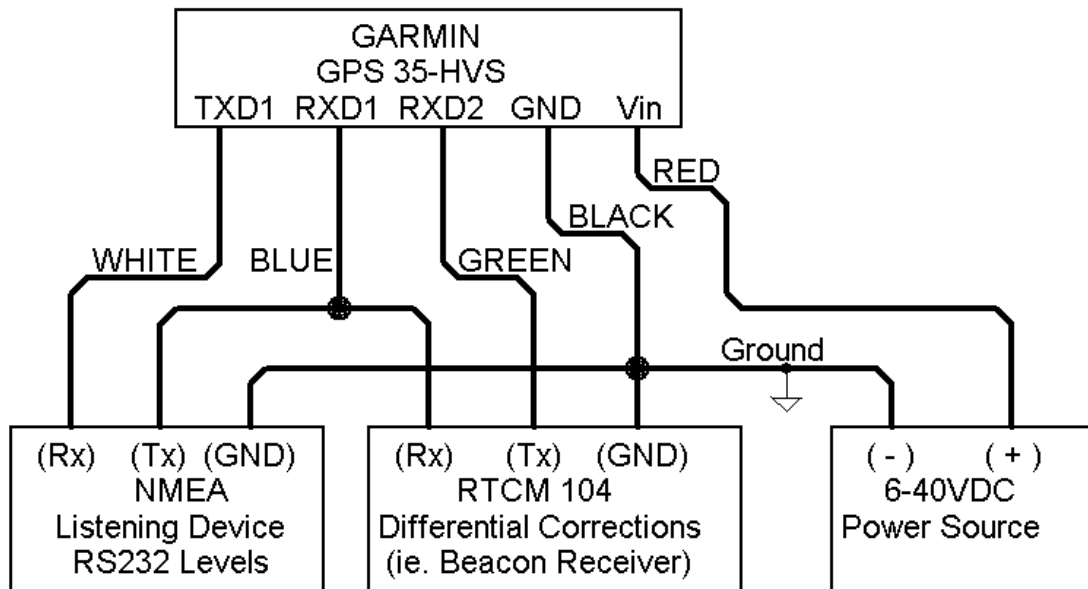

Fig. 1, TYPICAL APPLICATION ARCHITECTURE

SECTION 2

OPERATIONAL CHARACTERISTICS

This section describes the basic operational characteristics of the GPS 35LP. Additional information regarding input and output specifications are contained in Section 4.

2.1 SELF TEST

After input power has been applied to the GPS 35LP and periodically thereafter, the unit will perform critical self test functions and report the results over the output channel(s). The following tests will be performed:

- 1) RAM check
- 2) FLASH memory test
- 3) Receiver test
- 4) Real-time clock test
- 5) Oscillator check

In addition to the results of the above tests, the GPS 35LP will report software version information.

2.2 INITIALIZATION

After the initial self test is complete, the GPS 35LP will begin the process of satellite acquisition and tracking. The acquisition process is fully automatic and, under normal circumstances, will take approximately 45 seconds to achieve a position fix (15 seconds if ephemeris data is known). After a position fix has been calculated, valid position, velocity and time information will be transmitted over the output channel(s).

Like all GPS receivers, the GPS 35LP utilizes initial data such as last stored position, date and time as well as satellite orbital data to achieve maximum acquisition performance. If significant inaccuracy exists in the initial data, or if the orbital data is obsolete, it may take 5.0 minutes to achieve a navigation solution. The GPS 35LP Autolocate™ feature is capable of automatically determining a navigation solution without intervention from the host system. However, acquisition performance can be improved if the host system initializes the GPS 35LP following the occurrence of one or more of the following events:

- 1) Transportation over distances further than 1500 kilometers
- 2) Failure of the internal memory battery without system standby power
- 3) Stored date/time off by more than 30 minutes

See Section 4 for more information on initializing the GPS 35LP.

2.3 NAVIGATION

After the acquisition process is complete, the GPS 35LP will begin sending valid navigation information over its output channels. These data include:

- 1) Latitude/longitude/altitude
- 2) Velocity
- 3) Date/time
- 4) Error estimates
- 5) Satellite and receiver status

Normally the GPS 35LP will select the optimal navigation mode (2D or 3D) based on available satellites and geometry considerations. The host system, at its option, may command the GPS 35LP to choose a specific mode of navigation, such as 2D. The following modes are available:

- 1) 2D exclusively with altitude supplied by the host system (altitude hold mode)
- 2) 3D exclusively with altitude computed by the GPS 35LP
- 3) Automatic mode in which the board set determines the desired mode based on satellite availability and geometry considerations

When navigating in the 2D mode (either exclusive or automatic), the GPS 35LP utilizes the last computed altitude or the last altitude supplied by the host system, whichever is newer. The host system must ensure that the altitude used for 2D navigation is accurate since the resulting position error may be as large as the altitude error. See Section 4 for more information on altitude control.

The GPS 35LP will default to automatic differential mode – “looking” for real-time differential corrections in RTCM SC-104 standard format, with message types 1,2,3, or 9, then attempt to apply them to the satellite data, in order to produce a differential (DGPS) solution. The host system, at its option, may also command the GPS 35LP to choose differential only mode. When navigating in the differential only mode, the GPS 35LP will output a position only when a differential solution is available.

2.4 SATELLITE DATA COLLECTION

The GPS 35LP will automatically update satellite orbital data as it operates. The intelligence of the GPS 35LP combined with its hardware capability allows these data to be collected and stored without intervention from the host system. A few key points should be considered regarding this process:

- 1) If the receiver is not operated for a period of six (6) months or more, the unit will “search the sky” in order to collect satellite orbital information. This process is fully automatic and, under normal circumstances, will take 3-4 minutes to achieve a navigation solution. However, the host system should allow the board set to remain on for at least 12.5 minutes after the first satellite is acquired (see Section 4 for more information on status indications).
- 2) If the memory backup battery fails, the receiver will search the sky as described above. Should the memory battery discharge, the unit needs to be powered on for several days to insure a sufficient

recharge to maintain several months of clock operation and memory storage. System configuration information will not be lost due to battery discharge, only previous position, time and almanac data will be lost.

- 3) If the initial data is significantly inaccurate, the receiver perform an operation known as AutoLocate™. This procedure is fully automatic and, under normal circumstances, will require 1.5 minutes to calculate a navigation solution. AutoLocate™, unlike search the sky, does not require that the receiver continue to operate after a fix has been obtained.

SECTION 3

HARDWARE INTERFACE

3.1 MECHANICAL DIMENSIONS

The GPS 35LP is a complete GPS receiver including antenna in a uniquely styled waterproof package.

3.1.1 GPS 35 Dimensions

(General tolerance $\pm 0.50\text{mm}$)

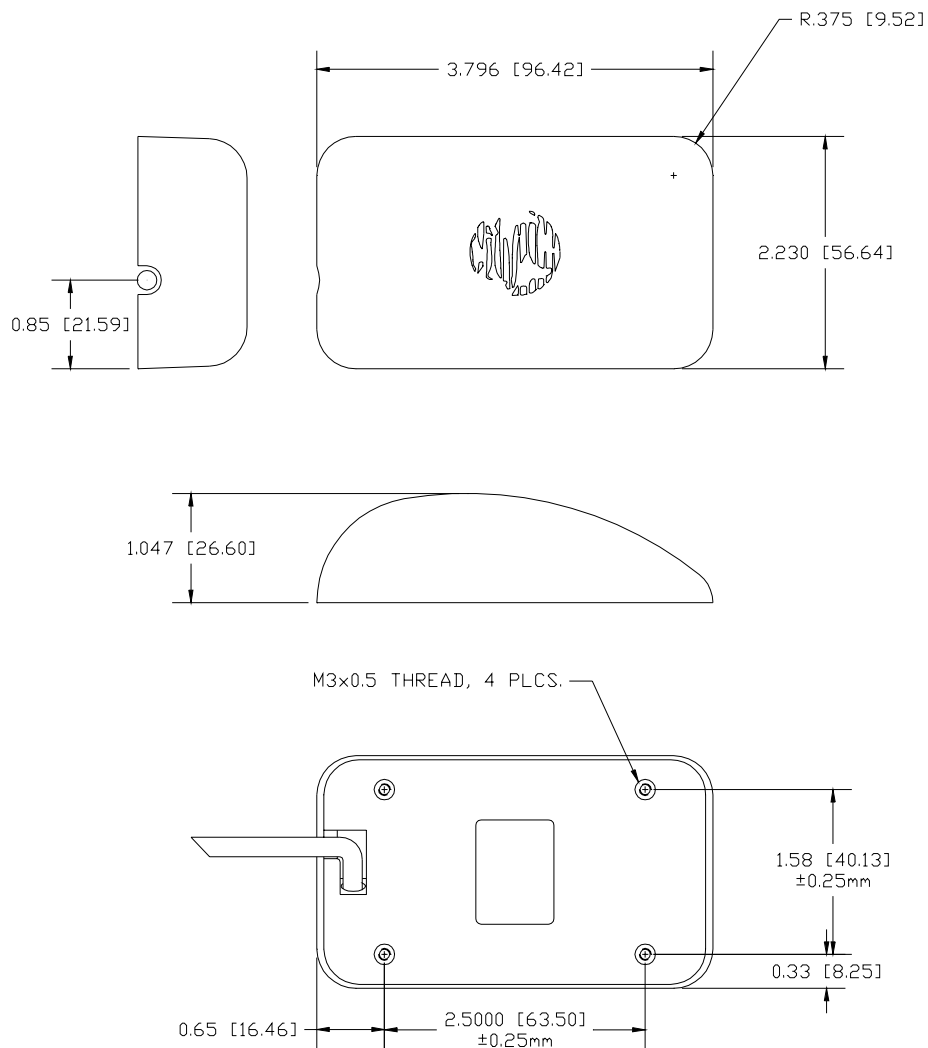

Fig. 2 GPS 35LP Dimensions

3.2 MOUNTING CONFIGURATIONS AND OPTIONS

The following mounting options are available for the GPS 35LP. Mounting is user configurable.

3.2.1 Magnetic Mount

The magnetic mount provides a firm, removable mounting attachment to any ferrous metal surface.

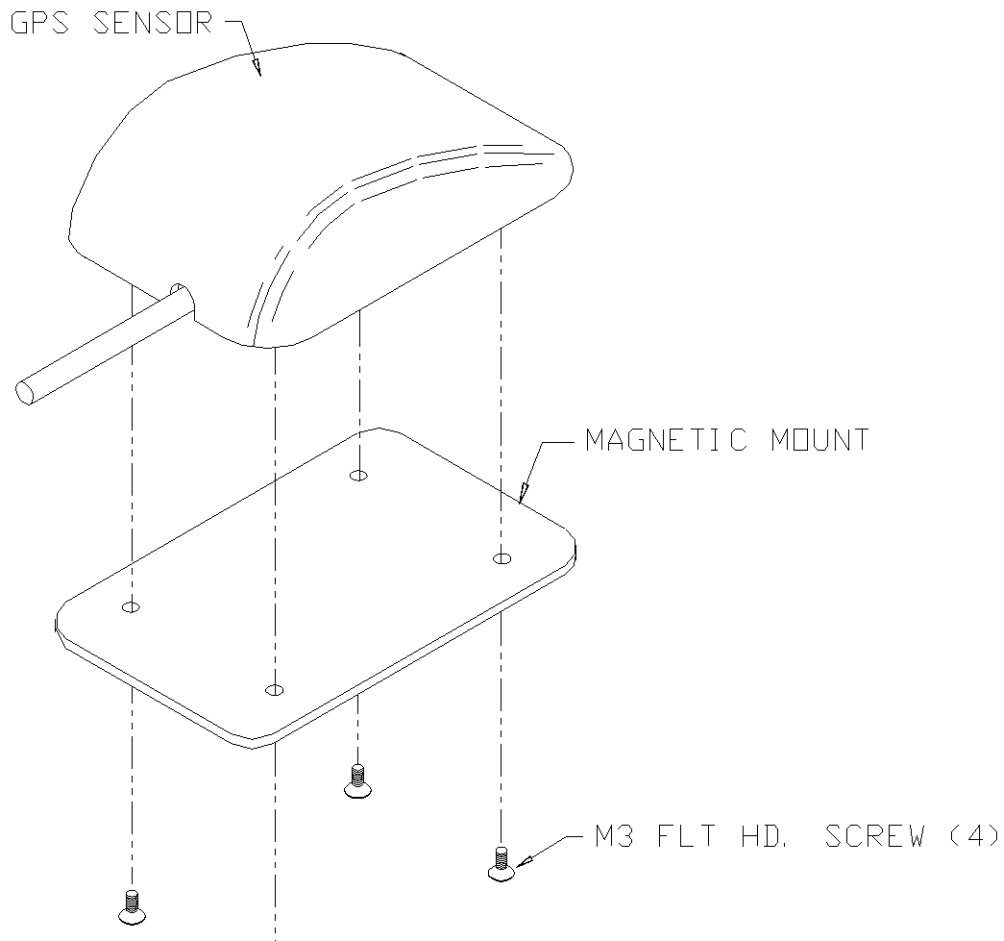

Fig. 3, Magnetic Mount Attachment

3.2.2 Trunk Lip Mount

The trunk lip mount provides a semi-permanent attachment to the trunk lip of most automobiles.

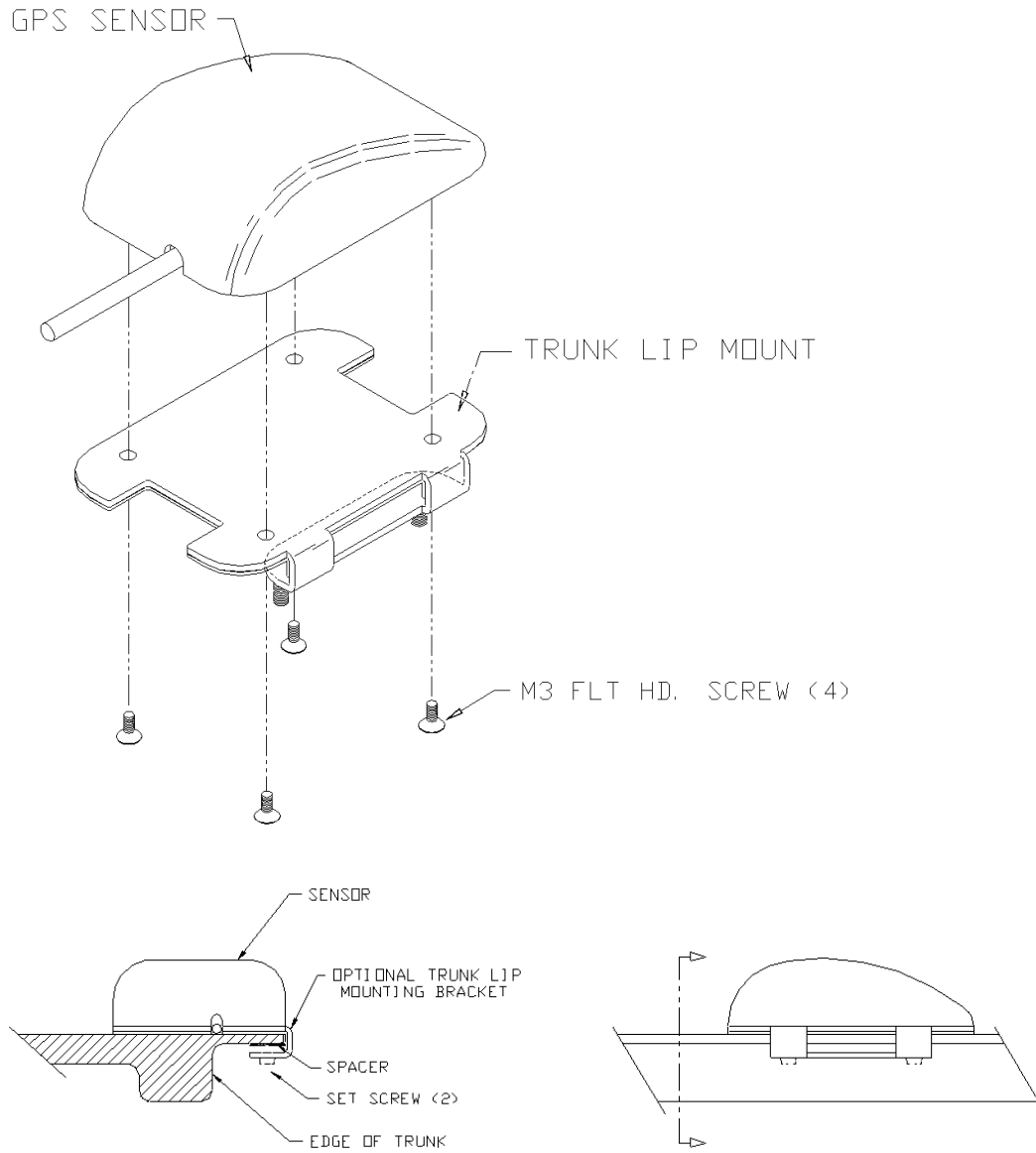

Fig. 4, Trunk Lip Mount Attachment

3.2.3 Suction Cup Mount

The suction cup bracket provides a removable mounting surface attached to the inside of a vehicle's windshield.

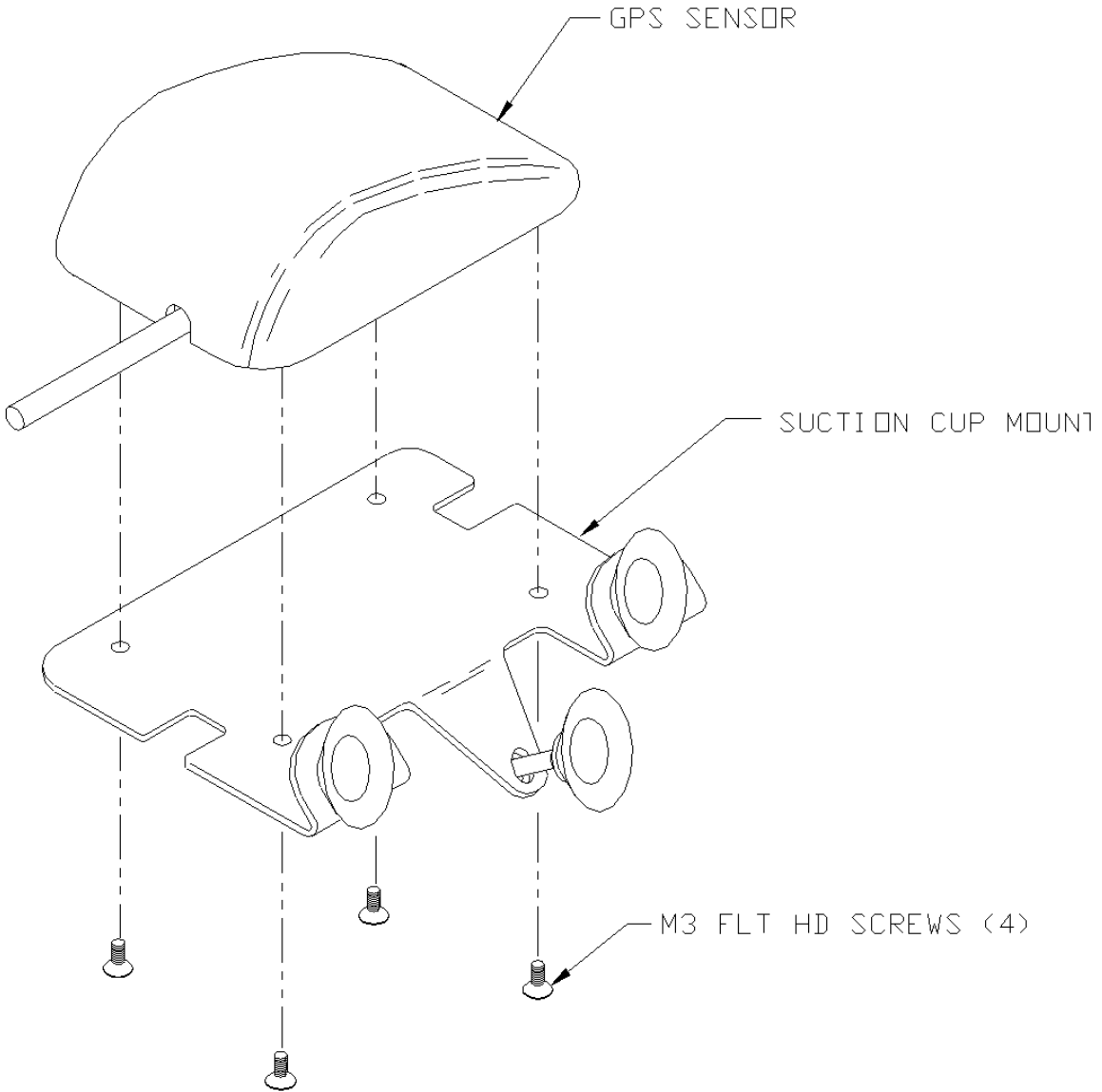

Fig. 5, Suction Cup Mount Attachment

3.2.4 Flange Mount

The flange mount allows for a permanent installation on a flat surface. This mounting configuration is ideal in applications in which the far side of the mounting surface is inaccessible.

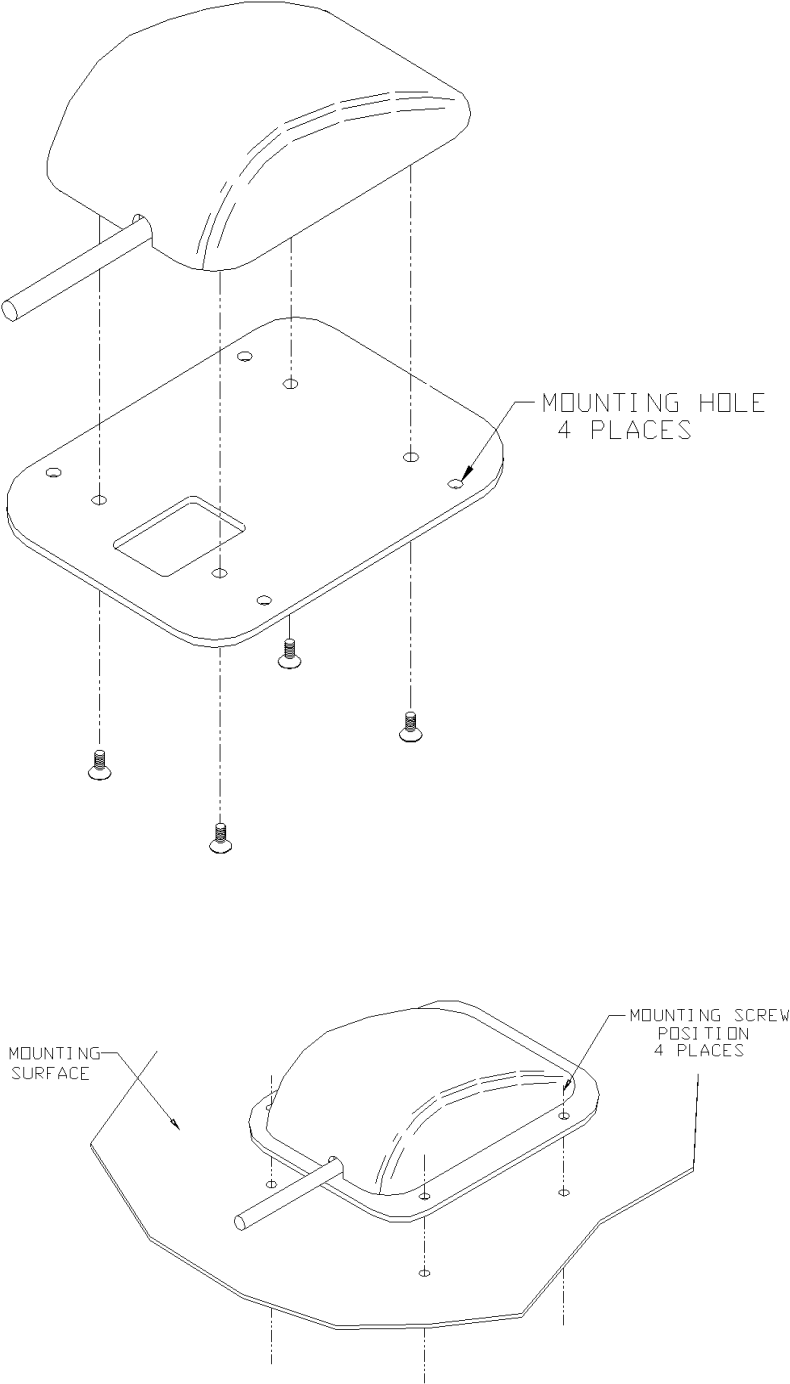

Fig. 6, Flange Mount Attachment

3.3 CONNECTION WIRING DESCRIPTION

The GPS 35LP features a stripped and pre-tinned cable assembly for connection flexibility. The following is a functional description of each wire in the cable assembly.

Red: Vin - Regulated +3.6V to +6V, 150 mA (maximum) in the -LVx versions. Typical operating current is 120 mA. Transients and overvoltages are protected by an internal 6.8V transient zener diode and a positive temperature coefficient thermistor. With voltages greater than 6.8Vdc the zener will draw several amps of current through the thermistor, causing it to heat rapidly and eventually power the unit off, unless an external fuse blows first. When proper supply voltages are returned, the thermistor will cool and allow the GPS 35-LVx to operate. The CMOS/TTL output buffers are powered by Vin, therefore a 3.6Vdc supply will create 3.6V logic output levels.

In the -HVx versions, Vin can be an unregulated 6.0Vdc to 40Vdc, optimized for 12Vdc. Typical operating power is 800mW This voltage drives a switching regulator with a nominal 4.4Vdc output, which powers the internal linear regulators, and the CMOS output buffers.

Black: GND - Power and Signal Ground

White: TXD1 - First Serial Asynchronous Output. CMOS/TTL output levels vary between 0V and Vin in the -LVC version. In the -LVS and -HVS versions a RS-232 compatible output driver is available. This output normally provides serial data which is formatted per "NMEA 0183, Version 2.0". Switchable to 300, 600, 1200, 2400, 4800, 9600 or 19200 BAUD. The default BAUD is 4800.

Blue: RXD1 - First Serial Asynchronous Input. RS-232 compatible with maximum input voltage range $-25 < V < 25$. This input may also be directly connected to standard 3 to 5Vdc CMOS logic. The minimum low signal voltage requirement is 0.8V, and the maximum high signal voltage requirement is 2.4V. Maximum load impedance is 4.7K ohms. This input may be used to receive serial initialization / configuration data, as specified in Section 4.1.

Purple: TXD2 - Second Serial Asynchronous Output. Electrically identical to TXD1. This output provides phase data information for software version 2.03 or above. See Appendix C for details.

Green: RXD2 - Second Serial Asynchronous Input. Electrically identical to RXD1. This input may be used to receive serial differential GPS data formatted per "RTCM Recommended Standards For Differential Navstar GPS Service, Version 2.1" (see Section 4 for more details).

Gray: PPS - One-Pulse-Per-Second Output. Typical voltage rise and fall times are 300 nSec. Impedance is 250 ohms. Open circuit output voltage is 0V and Vin in the -LVx versions, and 0V and 4.4V in the -HVx. The default format is a 100 millisecond high pulse at a 1Hz rate, the pulse width is programmable from a configuration command in 20msec increments. Rising edge is synchronized to the start of each GPS second. This output will provide a nominal 700 mVp-p signal into a 50 Ohm load. The pulse time measured at the 50% voltage point will be about 50 nSec earlier with a 50 Ohm load than with no load.

Yellow: POWER DOWN - External Power Down Input. Inactive if not connected or less than 0.5V. Active if greater than 2.7V. Typical switch point is 2.0V @ 0.34 mA. Input impedance is 15K Ohms. Activation of this input powers the internal regulators off and drops the supply current below 20mA in the -LVx versions, and below 1mA in the -HVx. The computer will be reset when power is restored.

Section 4

Software Interface

The GPS 35LP interface protocol design is based on the National Marine Electronics Association's NMEA 0183 ASCII interface specification, which is fully defined in "NMEA 0183, Version 2.0" (copies may be obtained from NMEA, P.O. Box 50040, Mobile, AL, 36605, USA) and the Radio Technical Commission for Maritime Services' "RTCM Recommended Standards For Differential Navstar GPS Service, Version 2.1, RTCM Special Committee No. 104" (copies may be obtained from RTCM, P.O. Box 19087, Washington, DC, 20036, USA). The GPS 35LP interface protocol, in addition to transmitting navigation information as defined by NMEA 0183, transmits additional information using the convention of GARMIN proprietary sentences.

The following sections describe the data format of each sentence transmitted and received by the GPS 35LP sensor. The baud rate selection, one-pulse-per-second output interfaces and RTCM differential GPS input are also described.

4.1 NMEA Received sentences

The subsequent paragraphs define the sentences which can be received on RXD1 by the GPS 35LP receivers. Null fields in the configuration sentence indicate no change in the particular configuration parameter.

All sentences received by the GPS 35LP must be terminated with <CR><LF>, but do not require the checksum *hh. The checksum is used for parity checking data and it is recommended that the checksum be used in environments containing high electromagnetic noise. It is generally not required in normal PC environments. Sentences may be truncated by <CR><LF> after any data field and valid fields up to that point will be acted on by the GPS 35LP.

4.1.1 Almanac Information (ALM)

\$GPALM,<1>,<2>,<3>,<4>,<5>,<6>,<7>,<8>,<9>,<10>,<11>,<12>,<13>,<14>,<15> *hh<CR><LF>

The \$GPALM sentence can be used to initialize the receivers stored almanac information if battery back-up has failed.

- <1> Total number of ALM sentences to be transmitted by the sensor board during almanac download. This field can be null or any number when sending almanac to the sensor board.
- <2> Number of current ALM sentence. This field can be null or any number when sending almanac to the sensor board.
- <3> Satellite PRN number, 01 to 32.
- <4> GPS week number.
- <5> SV health, bits 17-24 of each almanac page.
- <6> Eccentricity
- <7> Almanac reference time.
- <8> Inclination angle.
- <9> Rate of right ascension.
- <10> Root of semi major axis.
- <11> Omega, argument of perigee.
- <12> Longitude of ascension node.
- <13> Mean anomaly
- <14> afo clock parameter
- <15> af1 clock parameter

4.1.2 Sensor Initialization Information (PGRMI)

The \$PGRMI sentence provides information used to initialize the sensor board set position and time used for satellite acquisition. Receipt of this sentence by the board set causes the software to restart the satellite acquisition process. If there are no errors in the sentence, it will be echoed upon receipt. If an error is detected, the echoed PGRMI sentence will contain the current default values. Current PGRMI defaults can also be obtained by sending \$PGRMIE to the board.

\$PGRMI,<1>,<2>,<3>,<4>,<5>,<6>,<7>*hh<CR><LF>

- <1> Latitude, ddmm.mmm format (leading zeros must be transmitted)
- <2> Latitude hemisphere, N or S
- <3> Longitude, dddmm.mmm format (leading zeros must be transmitted)
- <4> Longitude hemisphere, E or W
- <5> Current UTC date, ddmmyy format
- <6> Current UTC time, hhmmss format
- <7> Receiver Command, A = Auto Locate, R = Unit Reset.

4.1.3 Sensor Configuration Information (PGRMC)

The \$PGRMC sentence provides information used to configure the sensor board operation. Configuration parameters are stored in non-volatile memory and retained between power cycles. The GPS 35LP will echo this sentence upon its receipt if no errors are detected. If an error is detected, the echoed PGRMC sentence will contain the current default values. Current default values can also be obtained by sending \$PGRMCE to the board.

\$PGRMC,<1>,<2>,<3>,<4>,<5>,<6>,<7>,<8>,<9>,<10>,<11>,<12>,<13>,<14>*hh<CR><LF>

- <1> Fix mode, A = automatic, 2 = 2D exclusively (host system must supply altitude), 3 = 3D exclusively
- <2> Altitude above/below mean sea level, -1500.0 to 18000.0 meters
- <3> Earth datum index. If the user datum index (96) is specified, fields <4> through <8> must contain valid values. Otherwise, fields <4> through <8> must be null. Refer to Appendix A for a list of earth datums and the corresponding earth datum index.
- <4> User earth datum semi-major axis, 6360000.0 to 6380000.0 meters (.001 meters resolution)
- <5> User earth datum inverse flattening factor, 285.0 to 310.0 (10^{-9} resolution)
- <6> User earth datum delta x earth centered coordinate, -5000.0 to 5000.0 meters (1 meter resolution)
- <7> User earth datum delta y earth centered coordinate, -5000.0 to 5000.0 meters (1 meter resolution)
- <8> User earth datum delta z earth centered coordinate, -5000.0 to 5000.0 meters (1 meter resolution)
- <9> Differential mode, A = automatic (output DGPS data when available, non-DGPS otherwise), D = differential exclusively (output only differential fixes)
- <10> NMEA Baud rate, 1 = 1200, 2 = 2400, 3 = 4800, 4 = 9600, 5 = 19200, 6 = 300, 7 = 600
- <11> Velocity filter, 0 = No filter, 1 = Automatic filter, 2-255 = Filter time constant (10 = 10 second filter)
- <12> PPS mode, 1 = No PPS, 2 = 1 Hz
- <13> PPS pulse length, 0-48 = $(n+1)*20$ msec. Example $n = 4 \Rightarrow 100$ msec pulse
- <14> Dead reckoning valid time 1-30 (sec)

All configuration changes take effect after receipt of a valid value except baud rate and PPS mode. Baud rate and PPS mode changes take effect on the next power cycle or an external reset event.

4.1.4 Additional Sensor Configuration Information (PGRMC1)

The \$PGRMC1 sentence provides additional information used to configure the sensor board operation. Configuration parameters are stored in non-volatile memory and retained between power cycles. The GPS 35LP will echo this sentence upon its receipt if no errors are detected. If an error is detected, the echoed PGRMC1 sentence will contain the current default values. Current default values can also be obtained by sending \$PGRMC1E to the board.

\$PGRMC1,<1>,<2>*hh<CR><LF>

<1> NMEA output time 1-900 (sec).

<2> Binary Phase Output Data, 1 = Off, 2 = On.

Configuration changes take effect on the next power cycle or an external reset event.

4.1.5 Output Sentence Enable/Disable (PGRMO)

The \$PGRMO sentence provides the ability to enable and disable specific output sentences.

The following sentences are enabled at the factory: GPGSA, GPGSV, GPRMC, PGRME, PGRMT and PGRMV

\$PGRMO,<1>,<2>*hh<CR><LF>

<1> Target sentence description (e.g., PGRMT, GPGSV, etc.)

<2> Target sentence mode, where:
0 = disable specified sentence
1 = enable specified sentence
2 = disable all output sentences
3 = enable all output sentences (except GPALM)

The following notes apply to the PGRMO input sentence:

- 1) If the target sentence mode is '2' (disable all) or '3' (enable all), the target sentence description is not checked for validity. In this case, an empty field is allowed (e.g., \$PGRMO,,3), or the mode field may contain from 1 to 5 characters.
- 2) If the target sentence mode is '0' (disable) or '1' (enable), the target sentence description field must be an identifier for one of the sentences being output by the GPS 25LP.
- 3) If either the target sentence mode field or the target sentence description field is not valid, the PGRMO sentence will have no effect.
- 4) \$PGRMO,GPALM,1 will cause the sensor board to transmit all stored almanac information. All other NMEA sentence transmission will be temporarily suspended.

4.2 NMEA Transmitted Sentences

The subsequent paragraphs define the sentences which can be transmitted on TXD1 by the GPS 35LP receivers.

4.2.1 Sentence Transmission Rate

Sentences are transmitted with respect to the user selected baud rate.

Regardless of the selected baud rate, the information transmitted by the GPS 35LP is referenced to the one-pulse-per-second output pulse immediately preceding the GPRMC sentence.

The GPS 35LP will transmit each sentence (except where noted in particular transmitted sentence descriptions) at a periodic rate based on the user selected baud rate and user selected output sentences. The sensor board will transmit the selected sentences contiguously. The contiguous transmission starts at a GPS second boundary. The length of the transmission can be determined by the following equation and tables:

$$\text{length} = \frac{\text{total characters to be transmitted}}{\text{characters transmitted per sec}}$$

Baud	characters_transmitted_per_sec
300	30
600	60
1200	120
2400	240
4800	480
9600	960
19200	1920

Sentence	max_characters
GPGGA	81
GPGSA	66
GPGSV	210
GPRMC	73
GPVTG	40
PGRME	35
PGRMT	50
PGRMV	32
PGRMF	82
LCGLL	41
LCVTG	37

The maximum number of fields allowed in a single sentence is 82 characters including delimiters. Values in the table include the sentence start delimiter character "\$" and the termination delimiter <CR><LF>.

The factory set defaults will result in a once per second transmission at the NMEA specification transmission rate of 4800 baud.

4.2.2 Transmitted Time

The GPS 35LP receivers output UTC (Coordinated Universal Time) date and time of day in the transmitted sentences. Prior to the initial position fix, the date and time of day are provided by the on-board clock. After the initial position fix, the date and time of day are calculated using GPS satellite information and are synchronized with the one-pulse-per-second output.

The GPS 35LP uses information obtained from the GPS satellites to add or delete UTC leap seconds and correct the transmitted date and time of day. The transmitted date and time of day for leap second correction follow the guidelines in “*National Institute of Standards and Technology Special Publication 432 (Revised 1990)*” (for sale by the Superintendent of Documents, U.S. Government Printing Office, Washington, DC, 20402, USA).

When a positive leap second is required, the second is inserted beginning at 23h 59m 60s of the last day of a month and ending at 0h 0m 0s of the first day of the following month. The minute containing the leap second is 61 seconds long. The GPS 35LP would have transmitted this information for the leap second added December 31, 1989 as follows:

<u>Date</u>	<u>Time</u>
311289	235959
311289	235960
010190	000000

If a negative leap second should be required, one second will be deleted at the end of some UTC month. The minute containing the leap second will be only 59 seconds long. In this case, the GPS 35LP will not transmit the time of day 23h 59m 59s for the day from which the leap second is removed.

4.2.3 Global Positioning System Almanac Data (ALM)

<field information> can be found in section 4.1.1.

\$GPALM,<1>,<2>,<3>,<4>,<5>,<6>,<7>,<8>,<9>,<10>,<11>,<12>,<13>,<14>,<15>*hh<CR><LF>

Almanac sentences are not normally transmitted. Almanac transmission can be initiated by sending the sensor board a \$PGRMO,GPALM,1 command. Upon receipt of this command the sensor board will transmit available almanac information on GPALM sentences. During the transmission of almanac sentences other NMEA data output will be temporarily suspended.

<field information> can be found in section 4.1.1.

4.2.4 Global Positioning System Fix Data (GGA)

\$GPGGA,<1>,<2>,<3>,<4>,<5>,<6>,<7>,<8>,<9>,M,<10>,M,<11>,<12>*hh<CR><LF>

- <1> UTC time of position fix, hhhmss format
- <2> Latitude, ddm.mmmm format (leading zeros will be transmitted)
- <3> Latitude hemisphere, N or S
- <4> Longitude, dddmm.mmmm format (leading zeros will be transmitted)
- <5> Longitude hemisphere, E or W

- <6> GPS quality indication,
0 = fix not available,
1 = Non-differential GPS fix available,
2 = Differential GPS (DGPS) fix available
- <7> Number of satellites in use, 00 to 12 (leading zeros will be transmitted)
- <8> Horizontal dilution of precision, 0.5 to 99.9
- <9> Antenna height above/below mean sea level, -9999.9 to 99999.9 meters
- <10> Geoidal height, -999.9 to 9999.9 meters
- <11> Differential GPS (RTCM SC-104) data age, number of seconds since last valid RTCM transmission (null if non-DGPS)
- <12> Differential Reference Station ID, 0000 to 1023 (leading zeros transmitted, null if non-DGPS)

4.2.5 GPS DOP and Active Satellites (GSA)

\$GPGSA,<1>,<2>,<3>,<3>,<3>,<3>,<3>,<3>,<3>,<3>,<3>,<3>,<3>,<3>,<4>,<5>,<6>*hh<CR><LF>

- <1> Mode, M = manual, A = automatic
- <2> Fix type, 1 = not available, 2 = 2D, 3 = 3D
- <3> PRN number, 01 to 32, of satellite used in solution, up to 12 transmitted (leading zeros will be transmitted)
- <4> Position dilution of precision, 0.5 to 99.9
- <5> Horizontal dilution of precision, 0.5 to 99.9
- <6> Vertical dilution of precision, 0.5 to 99.9

4.2.6 GPS Satellites in View (GSV)

\$GPGSV,<1>,<2>,<3>,<4>,<5>,<6>,<7>,...<4>,<5>,<6>,<7>*hh<CR><LF>

- <1> Total number of GSV sentences to be transmitted
- <2> Number of current GSV sentence
- <3> Total number of satellites in view, 00 to 12 (leading zeros will be transmitted)
- <4> Satellite PRN number, 01 to 32 (leading zeros will be transmitted)
- <5> Satellite elevation, 00 to 90 degrees (leading zeros will be transmitted)
- <6> Satellite azimuth, 000 to 359 degrees, true (leading zeros will be transmitted)
- <7> Signal to noise ratio (C/No) 00 to 99 dB, null when not tracking (leading zeros will be transmitted)

NOTE: Items <4>,<5>,<6> and <7> repeat for each satellite in view to a maximum of four (4) satellites per sentence. Additional satellites in view information must be sent in subsequent sentences. These fields will be null if unused.

4.2.7 Recommended Minimum Specific GPS/TRANSIT Data (RMC)

\$GPRMC,<1>,<2>,<3>,<4>,<5>,<6>,<7>,<8>,<9>,<10>,<11>*hh<CR><LF>

- <1> UTC time of position fix, hhmmss format
- <2> Status, A = Valid position, V = NAV receiver warning
- <3> Latitude, ddmm.mmmm format (leading zeros will be transmitted)
- <4> Latitude hemisphere, N or S
- <5> Longitude, dddmm.mmmm format (leading zeros will be transmitted)
- <6> Longitude hemisphere, E or W
- <7> Speed over ground, 0.0 to 1851.8 knots
- <8> Course over ground, 000.0 to 359.9 degrees, true (leading zeros will be transmitted)
- <9> UTC date of position fix, ddmmyy format
- <10> Magnetic variation, 000.0 to 180.0 degrees (leading zeros will be transmitted)
- <11> Magnetic variation direction, E or W (westerly variation adds to true course)

4.2.8 Track Made Good and Ground Speed with GPS Talker ID (VTG)

The GPVTG sentence reports track and velocity information with a checksum:

\$GPVTG,<1>,T,<2>,M,<3>,N,<4>,K*hh<CR><LF>

- <1> True course over ground, 000 to 359 degrees (leading zeros will be transmitted)
- <2> Magnetic course over ground, 000 to 359 degrees (leading zeros will be transmitted)
- <3> Speed over ground, 00.0 to 999.9 knots (leading zeros will be transmitted)
- <4> Speed over ground, 00.0 to 1851.8 kilometers per hour (leading zeros will be transmitted)

4.2.9 Geographic Position with LORAN Talker ID (LCGLL)

The LCGLL sentence reports position information.

\$LCGLL,<1>,<2>,<3>,<4>,<5>,<CR><LF>

- <1> Latitude, ddm.mmm format (leading zeros will be transmitted)
- <2> Latitude hemisphere, N or S
- <3> Longitude, dddmm.mmm format (leading zeros will be transmitted)
- <4> Longitude hemisphere, E or W
- <5> UTC time of position fix, hhmmss format

4.2.10 Track Made Good and Ground Speed with LORAN Talker ID (LCVTG)

The LCVTG sentence reports track and velocity information.

\$LCVTG,<1>,T,<2>,M,<3>,N,<4>,K<CR><LF>

- <1> True course over ground, 000 to 359 degrees (leading zeros will be transmitted)
- <2> Magnetic course over ground, 000 to 359 degrees (leading zeros will be transmitted)
- <3> Speed over ground, 00.0 to 999.9 knots (leading zeros will be transmitted)
- <4> Speed over ground, 00.0 to 1851.8 kilometers per hour (leading zeros will be transmitted)

4.2.11 Estimated Error Information (PGRME)

The GARMIN Proprietary sentence \$PGRME reports estimated position error information.

\$PGRME,<1>,M,<2>,M,<3>,M*hh<CR><LF>

- <1> Estimated horizontal position error (HPE), 0.0 to 999.9 meters
- <2> Estimated vertical position error (VPE), 0.0 to 999.9 meters
- <3> Estimated position error (EPE), 0.0 to 999.9 meters

4.2.12 GPS Fix Data Sentence (PGRMF)

The sentence \$PGRME is GARMIN Proprietary format.

\$PGRMF,<1>,<2>,<3>,<4>,<5>,<6>,<7>,<8>,<9>,<10>,<11>,<12>,<13>,<14>,<15>*hh<CR><LF>

- <1> GPS week number (0 - 1023)
- <2> GPS seconds (0 - 604799)
- <3> UTC date of position fix, ddmmyy format
- <4> UTC time of position fix, hhmmss format
- <5> GPS leap second count
- <6> Latitude, ddm.mmmm format (leading zeros will be transmitted)
- <7> Latitude hemisphere, N or S
- <8> Longitude, dddmm.mmmm format (leading zeros will be transmitted)
- <9> Longitude hemisphere, E or W
- <10> Mode, M = manual, A = automatic
- <11> Fix type, 0 = no fix, 1 = 2D fix, 2 = 3D fix
- <12> Speed over ground, 0 to 1851 kilometers/hour
- <13> Course over ground, 0 to 359 degrees, true
- <14> Position dilution of precision, 0 to 9 (rounded to nearest integer value)
- <15> Time dilution of precision, 0 to 9 (rounded to nearest integer value)

4.2.13 Sensor Status Information (PGRMT)

The GARMIN Proprietary sentence \$PGRMT gives information concerning the status of the sensor board. This sentence is transmitted once per minute regardless of the selected baud rate.

\$PGRMT,<1>,<2>,<3>,<4>,<5>,<6>,<7>,<8>,<9>*hh<CR><LF>

- <1> Product, model and software version (variable length field, e.g., "GPS 25LP VER 1.10")
- <2> ROM checksum test, P = pass, F = fail
- <3> Receiver failure discrete, P = pass, F = fail
- <4> Stored data lost, R = retained, L = lost
- <5> Real time clock lost, R = retained, L = lost
- <6> Oscillator drift discrete, P = pass, F = excessive drift detected
- <7> Data collection discrete, C = collecting, null if not collecting
- <8> Board temperature in degrees C
- <9> Board configuration data, R = retained, L = lost

4.2.14 3D velocity Information (PGRMV)

The GARMIN Proprietary sentence \$PGRMV reports three-dimensional velocity information.

\$PGRMV,<1>,<2>,<3>*hh<CR><LF>

- <1> True east velocity, -514.4 to 514.4 m/second
- <2> True north velocity, -514.4 to 514.4 m/second
- <3> Up velocity, -999.9 to 9999.9 m/second

4.3 Baud Rate Selection

Baud rate selection can be performed by sending the appropriate configuration sentence to the sensor board as described in the NMEA input sentences selection. (Section 4.1)

4.4 One-Pulse-Per-Second Output

The highly accurate one-pulse-per-second output is provided for applications requiring precise timing measurements. The signal is generated after the initial position fix has been calculated and continues until power down. The rising edge of the signal is synchronized to the start of each GPS second.

Regardless of the selected baud rate, the information transmitted by the GPS 35LP receiver is referenced to the pulse immediately preceding the NMEA 0183 RMC sentence.

The accuracy of the one-pulse-per-second output is maintained only while the GPS 35LP can compute a valid position fix. To obtain the most accurate results, the one-pulse-per-second output should be calibrated against a local time reference to compensate for cable and internal receiver delays and the local time bias.

The default pulse width is 100 msec, however; it may be programmed in 20 msec increments between 20 msec and 980 msec as described in \$PGRMC Section 4.1.3 character <13>.

4.5 RTCM Received Data

Position accuracy of less than 5 meters can be achieved with the GPS 35LP by using Differential GPS (DGPS) real-time pseudo-range correction data in RTCM SC-104 format, with message types 1, 2, 3, and 9. These corrections can be received by the GPS 35LP receiver on RXD2. Correction data at speeds of 300, 600, 1200, 2400, 4800 or 9600 baud can be utilized, as the GPS 35LP automatically detects the incoming baud rate. For details on the SC-104 format, refer to RTCM Paper 134-89/SC 104-68 by the Radio Technical Commission for Maritime Services.

Appendix A

Earth Datums

The following is a list of the GARMIN GPS 35LP earth datum indexes and the corresponding earth datum name (including the area of application):

0	ADINDAN - Ethiopia, Mali, Senegal, Sudan
1	AFGOOYE - Somalia
2	AIN EL ABD 1970 - Bahrain Island, Saudi Arabia
3	ANNA 1 ASTRO 1965 - Cocos Island
4	ARC 1950 - Botswana, Lesotho, Malawi, Swaziland, Zaire, Zambia, Zimbabwe
5	ARC 1960 - Kenya, Tanzania
6	ASCENSION ISLAND 1958 - Ascension Island
7	ASTRO BEACON "E" - Iwo Jima Island
8	AUSTRALIAN GEODETIC 1966 - Australia, Tasmania Island
9	AUSTRALIAN GEODETIC 1984 - Australia, Tasmania Island
10	ASTRO DOS 71/4 - St. Helena Island
11	ASTRONOMIC STATION 1952 - Marcus Island
12	ASTRO B4 SOROL ATOLL - Tern Island
13	BELLEVUE (IGN) - Efate and Erromango Islands
14	BERMUDA 1957 - Bermuda Islands
15	BOGOTA OBSERVATORY - Colombia
16	CAMPO INCHAUSPE - Argentina
17	CANTON ASTRO 1966 - Phoenix Islands
18	CAPE CANAVERAL - Florida, Bahama Islands
19	CAPE - South Africa
20	CARTHAGE - Tunisia
21	CHATHAM 1971 - Chatham Island (New Zealand)
22	CHUA ASTRO - Paraguay
23	CORREGO ALEGRE - Brazil
24	DJAKARTA (BATAVIA) - Sumatra Island (Indonesia)
25	DOS 1968 - Gizo Island (New Georgia Islands)
26	EASTER ISLAND 1967 - Easter Island
27	EUROPEAN 1950 - Austria, Belgium, Denmark, Finland, France, Germany, Gibraltar, Greece, Italy, Luxembourg, Netherlands, Norway, Portugal, Spain, Sweden, Switzerland
28	EUROPEAN 1979 - Austria, Finland, Netherlands, Norway, Spain, Sweden, Switzerland
29	FINLAND HAYFORD 1910 - Finland
30	GANDAJIKA BASE - Republic of Maldives
31	GEODETIC DATUM 1949 - New Zealand
32	ORDNANCE SURVEY OF GREAT BRITAIN 1936 - England, Isle of Man, Scotland, Shetland Islands, Wales
33	GUAM 1963 - Guam Island
34	GUX 1 ASTRO - Guadalcanal Island
35	HJORSEY 1955 - Iceland
36	HONG KONG 1963 - Hong Kong
37	INDIAN - Bangladesh, India, Nepal
38	INDIAN - Thailand, Vietnam
39	IRELAND 1965 - Ireland

40 ISTS 073 ASTRO 1969 - Diego Garcia
 41 JOHNSTON ISLAND 1961 - Johnston Island
 42 KANDAWALA - Sri Lanka
 43 KERGUELEN ISLAND - Kerguelen Island
 44 KERTAU 1948 - West Malaysia, Singapore
 45 L.C. 5 ASTRO - Cayman Brac Island
 46 LIBERIA 1964 - Liberia
 47 LUZON - Mindanao Island
 48 LUZON - Phillippines (excluding Mindanao Island)
 49 MAHE 1971 - Mahe Island
 50 MARCO ASTRO - Salvage Islands
 51 MASSAWA - Eritrea (Ethiopia)
 52 MERCHICH - Morocco
 53 MIDWAY ASTRO 1961 - Midway Island
 54 MINNA - Nigeria
 55 NORTH AMERICAN 1927 - Alaska
 56 NORTH AMERICAN 1927 - Bahamas (excluding San Salvador Island)
 57 NORTH AMERICAN 1927 - Central America (Belize, Costa Rica, El Salvador,
 Guatemala, Honduras, Nicaragua)
 58 NORTH AMERICAN 1927 - Canal Zone
 59 NORTH AMERICAN 1927 - Canada (including Newfoundland Island)
 60 NORTH AMERICAN 1927 - Caribbean (Barbados, Caicos Islands, Cuba, Dominican
 Republic, Grand Cayman, Jamaica, Leeward Islands, Turks Islands)
 61 NORTH AMERICAN 1927 - Mean Value (CONUS)
 62 NORTH AMERICAN 1927 - Cuba
 63 NORTH AMERICAN 1927 - Greenland (Hayes Peninsula)
 64 NORTH AMERICAN 1927 - Mexico
 65 NORTH AMERICAN 1927 - San Salvador Island
 66 NORTH AMERICAN 1983 - Alaska, Canada, Central America, CONUS, Mexico
 67 NAPARIMA, BWI - Trinidad and Tobago
 68 NAHRWAN - Masirah Island (Oman)
 69 NAHRWAN - Saudi Arabia
 70 NAHRWAN - United Arab Emirates
 71 OBSERVATORIO 1966 - Corvo and Flores Islands (Azores)
 72 OLD EGYPTIAN - Egypt
 73 OLD HAWAIIAN - Mean Value
 74 OMAN - Oman
 75 PICO DE LAS NIEVES - Canary Islands
 76 PITCAIRN ASTRO 1967 - Pitcairn Island
 77 PUERTO RICO - Puerto Rico, Virgin Islands
 78 QATAR NATIONAL - Qatar
 79 QORNOQ - South Greenland
 80 REUNION - Mascarene Island
 81 ROME 1940 - Sardinia Island
 82 RT 90 - Sweden
 83 PROVISIONAL SOUTH AMERICAN 1956 - Bolivia, Chile, Colombia, Ecuador, Guyana,
 Peru, Venezuela
 84 SOUTH AMERICAN 1969 - Argentina, Bolivia, Brazil, Chile, Colombia, Ecuador, Guyana,
 Paraguay, Peru, Venezuela, Trinidad and Tobago
 85 SOUTH ASIA - Singapore
 86 PROVISIONAL SOUTH CHILEAN 1963 - South Chile
 87 SANTO (DOS) - Espirito Santo Island

- 88 SAO BRAZ - Sao Miguel, Santa Maria Islands (Azores)
- 89 SAPPER HILL 1943 - East Falkland Island
- 90 SCHWARZECK - Namibia
- 91 SOUTHEAST BASE - Porto Santo and Madeira Islands
- 92 SOUTHWEST BASE - Faial, Graciosa, Pico, Sao Jorge, and Terceira Islands (Azores)
- 93 TIMBALAI 1948 - Brunei and East Malaysia (Sarawak and Sabah)
- 94 TOKYO - Japan, Korea, Okinawa
- 95 TRISTAN ASTRO 1968 - Tristan da Cunha
- 96 User defined earth datum
- 97 VITI LEVU 1916 - Viti Levu Island (Fiji Islands)
- 98 WAKE-ENIWETOK 1960 - Marshall Islands
- 99 WORLD GEODETIC SYSTEM 1972
- 100 WORLD GEODETIC SYSTEM 1984
- 101 ZANDERIJ - Surinam
- 102 CH-1903 - Switzerland
- 103 Hu - Tzu - Shan
- 104 Indonesia 74
- 105 Austria
- 106 Potsdam
- 107 Taiwan (modified Hu-Tzu-Shan)

Appendix B

GPS 35LP Evaluation Kits

GPS 35LP evaluation materials kit (part number 010-10186-00) is available from Garmin International. This kit includes two DB-9 connectors with solder pots, various mounting brackets, hookup wire, technical specification, and software to monitor the GPS 35LP outputs and configure the receiver.

To install the evaluation and configuration software run the program, **setup**, by using the FILE - RUN command in Windows.

NMEAVWR.EXE

The **NMEAVWR.EXE** program in the GARMIN program group can accept NMEA data from either the com1 or com2 PC serial port at 1200, 2400, 4800, 9600 or 19200 baud. The default settings are com1 at 4800 baud. NMEAVWR receives NMEA sentences and displays sentence information in a formatted display on the screen.

The top portion of the screen displays the 5 character identifier of sentences received, the age in seconds since the last transmission, and a count of the number of times the sentence has been received. The middle portion of the screen displays the most recently received data in the sentence with the selected NMEA identifier (highlighted in the top portion of the screen using the arrow keys).

The lower portion contains a formatted presentation of the currently selected sentence. In addition to receiving data the program will also upload NMEA sentences to the sensor board. The ALT-U key sequence will upload the file NMEA.TXT in the current directory to the unit. Received data can also be logged to a file. NMEAVWR can be invoked from a DOS prompt with the following optional parameters:

```
<path>nmeavwr [/b:<baud>] [<port>] [log_file.txt]
```

where:

[]	brackets indicate optional parameters
<path>	DOS path to nmeavwr.exe if not in current directory
<baud>	baud rate
<port>	PC communications port
log_file.txt	ASCII log file of all received sentences

Example:

```
c:\garmin>nmeavwr /b:9600 com2 log_file.txt
```

If no options are used, the defaults are 4800 baud, com1, and no data logging.

GPSCFG.EXE

The configuration program **GPSCFG.EXE** will configure the sensor boards based on user selected parameters. Some program features include the ability to download sensor board configuration, maintain different configurations in files, and perform sensor board configurations quickly with the use of one function key. Online program help is available.

GPS25PM.EXE

The Garmin Phase Monitor Program, **GPS25PM.EXE**, provides the following functions:

- Display and log phase data output from TXD2
- Upload almanac, position, and time information via RXD2
- Download almanac and ephemeris information upon command

GPS25PM.EXE can be invoked from a DOS prompt:

```
<path>gps25pm.exe [/com<x>] [/b:<yyyy>]
```

Where

<> denotes user supplied information

[] denotes optional parameters

x is com port number (1 or 2, default is 1)

yyyy is baud rate (1200, 2400, 4800, or 9600, default is 9600)

See Appendix C for detailed description and operation of the **GPS25PM.EXE** program.

Appendix C

Phase Output Data Binary Format

Two records are transmitted once per second by the GPS 35LP. One record contains primarily post-process information such as position and velocity information. The second record contains receiver measurement information. The records are sent at a default baud rate of 9600 baud, 8 bits, no parity.

Records begin with a delimiter byte (10 hex). The second byte identifies the record type (28 hex for a position record, 29 hex for a receiver measurement). The third byte indicates the size of the data. The fourth byte is the first byte of data. The data is then followed by a checksum byte, a delimiter byte (10 hex), and an end-of-transmission character (03 hex).

Note - If RTCM-104 differential data is sent to the GPS 35LP the board will reset the Phase Output Data baud rate to the same baud rate used for RTCM-104 data. If the differential inputs are used on the GPS 35LP then the RTCM-104 data must be sent to the GPS 35LP at 9600 baud (preferred) or 4800 baud. RTCM-104, baud rates less than 4800 baud are not supported by the GPS 35LP since it would limit bus bandwidth past the point where a once per second phase output data rate could be maintained.

Position Record

- 0x10 (dle is first byte)
- 0x28 (position record identifier)
- 0x36 (size of data)
- cpo_pvt_type (see description below)
- one byte checksum (the addition of bytes between the delimiters should equal 0)
- 0x10 (dle)
- 0x03 (etx is last byte)

typedef struct

```
{
float      alt;
float      epe;
float      eph;
float      epv;
int        fix;
double     gps_tow;
double     lat;
double     lon;
float      lon_vel;
float      lat_vel;
float      alt_vel;
} cpo_pvt_type;
```

alt ellipsoid altitude (mt)
epe est pos error (mt)
eph pos err, horizontal (mt)
epv pos err, vertical (mt)
fix 0 = no fix; 1 = no fix; 2 = 2D; 3 = 3D; 4 = 2D differential; 5 = 3D differential;
 6 and greater - not defined

gps_tow gps time of week (sec)
 lat Latitude (rad)
 lon Longitude (rad)
 lon_vel Longitude velocity (mt/sec)
 lat_vel Latitude velocity (mt/sec)
 alt_vel Altitude velocity (mt/sec)

Receiver Measurement Record

- 0x10 (dle is first byte)
 - 0x29 (receiver record identifier)
 - 0xE2 (size of data)
 - cpo_rcv_type (see below)
 - one byte chksum (the addition of bytes between the delimiters should equal 0)
 - 0x10 (dle)
 - 0x03 (etx)

typedef struct

```

{
  unsigned long            cycles;
  double                   pr;
  unsigned int             phase;
  char                     slp_dtct;
  unsigned char            snr_dbhz;
  char                     svid;
  char                     valid;
} cpo_rcv_sv_type;

```

typedef struct

```

{
  double                   rcvr_tow;
  int                      rcvr_wn;
  cpo_rcv_sv_type         sv[12];
} cpo_rcv_type;

```

rcvr_tow Receiver time of week (sec)
 rcvr_wn Receiver week number
 cycles Number of accumulated cycles
 pr pseudo range (mt)
 phase to convert to (0 -359.999) multiply by 360.0 and divide by 2048.0
 slp_dtct 0 = no cycle slip detected; non 0 = cycle slip detected
 snr_dbhz Signal strength
 svid Satellite number (0 - 31) Note - add 1 to offset to current svid numbers
 valid 0 = information not valid; non 0 = information valid

dle and etx bytes:

Software written to receive the two records should filter dle and etx bytes as described below:

```
typedef enum
{
    dat,
    dle,
    etx
} rx_state_type;
char          in_que[256];
int          in_que_ptr = 0;
rx_state_type rx_state = dat;

void add_to_que( char data )
{
#define          dle_byte 0x10
#define          etx_byte 0x03

    if (rx_state == dat)
    {
        if (data == dle_byte)
        {
            rx_state = dle;
        }
        else
        {
            in_que[ in_que_ptr++ ] = data;
        }
    }
    else if (rx_state == dle)
    {
        if (data == etx_byte)
        {
            rx_state = etx;
        }
        else
        {
            rx_state = dat;
            in_que[ in_que_ptr++ ] = data;
        }
    }
    else if (rx_state == etx)
    {
        if (data == dle_byte)
        {
            rx_state = dle;
        }
    }
}

if (in_que_ptr > 255)
{
    in_que_ptr = 0;
}
}
```

GARMIN Phase Monitor Program - gps25pm.exe

Command Line Arguments

default:

- /com1 - selects which PC serial port to use for communication - com1, com2 (com1 default).
- /b:9600 - selects the baud rate - 1200, 2400, 4800, or 9600 (9600 default)

Description:

GPS25PM.EXE is designed to interface with a Garmin GPS 25 XL or GPS 25LP sensor boards and the GPS 35LP sensors. The program will perform the following functions:

- display and log phase data output by GPS sensors.
- upload almanac, position, and time information.
- download almanac and ephemeris information.

GPS25PM.EXE is a DOS based program and will run on IBM 80286 or greater compatible PCs.

Displayed Information:

The GPS25PM.EXE display page is divided into 3 sections. The top-most section contains the following information updated at once a second:

A. Position

1. WGS 84 Latitude, Longitude (degrees - minutes) - 0.0001 minute resolution.
2. Ellipsoid Altitude (meters) - 1 meter resolution.

B. Velocity

1. Each of 3 axis (meters per second) - 0.01 m/s resolution.
2. Altitude (meters/minute) - 1 mt/m resolution.
3. Ground Speed (kilometers/hour) - 0.1 km/h resolution

C. Estimated Position Error - Vertical, Horizontal, Total (meters) - 1 meter resolution

D. Track - (0 - 359 degrees) - 0.1 degree resolution

E. Time

1. GPS time (hours - minutes - seconds) - 1 sec. resolution (not leap second corrected)
2. Receiver Time of Week (GPS seconds) - 0.00000001 sec. resolution.

The middle section contains receiver measurement information for satellites which the GPS sensor is currently tracking. This information is updated once at second:

A Satellite Number (1 - 32)

B. Signal to Noise Ratio (dbHz) - 1 dbHz resolution.

C. Phase (0 - 359 degrees) - 0.1 degree resolution.

D. Pseudo Range (meters) - 1 meter resolution.

E. Accumulated Cycles (cycles) - 1 cycle resolution.

The bottom section contains program messages. Upload and download status messages will appear here as well as any program error messages.

Commands:

D - Download Almanac:

The GPS25 sensor will be sent a command to download almanac information. GPS25PM.EXE will create the file ALMANAC.DAT and locate it the current working directory. If an ALMANAC.DAT exists in the current directory it will be over-written.

U - Upload Almanac:

The ALMANAC.DAT file located in the current working directory will be read, converted to GPS25 sensor binary format, and sent to the GPS25 sensor. This command will over-write any almanac information already in the GPS25 sensor.

E - Download Ephemeris:

The GPS25 sensor will be sent a command to download ephemeris information. GPS25PM.EXE will create the file EPHEMERS.DAT and locate it in the current working directory. If an EPHEMERIS.DAT exists in the current directory it will be over-written.

P - Position and Time Upload:

The program will prompt the user for the local time offset from UTC time. This offset is then used to determine UTC time from the PC's real time clock. The UTC time is then uploaded to the GPS25 sensor. If an error occurs in the upload process a 'COMM ERROR' will be enunciated on the screen. After the UTC time has been uploaded the user is prompted for Latitude and Longitude for position uploading. An integer Latitude and integer Longitude should be entered on the same line separated by a space. If the board has not yet obtained a position fix it will restart its startup sequence based on the new position and time information.

R - Record Data

The program will prompt the user for a data file name. GPS25XL.DAT is the default. Once the file name is obtained all information displayed in the top two sections of the screen will be formatted and written to the data file. The format of this data file is described in the File Formats section. If the R option is selected again, the current file will be saved and closed and a new file will be opened. Data files will be over-written if same names are used.

File Formats

ALMANAC.DAT

Example almanac entry:

```
**** Week 794 almanac for PRN-01 *****
ID:                01
Health:            000
Eccentricity:      3.414630890E-003
Time of Applicability(s): 380928.0000
Orbital Inclination(rad): 9.549833536E-001
Rate of Right Ascen(r/s): -7.771752131E-009
SQRT(A) (m1/2): 5153.589843
Right Ascen at TOA(rad): 8.032501489E-002
Argument of Perigee(rad): -1.308424592E+000
Mean Anom(rad):    2.045822620E+000
Af0(s):            9.536743164E-007
Af1(s/s):          8.367351256E-011
week:              794
```

Almanac information for satellites with a bad health status will not be included in this file when downloaded from the GPS25 sensor and should not be included when uploading to the GPS25 sensor.

EPHEMERS.DAT

Example ephemeris entry:

```
**** Week 794. Ephemeris for PRN-18 *****
Ref Time of Clk Parm(s): 233504.000000
Ref Time of Eph Parm(s): 233504.000000
Clk Cor, Group Dly(s): -8.280389E-006
Clk Correction af1(s/s): -3.410605E-013
Clk Correction af2(s/s/s): 0.000000E+000
User Range Accuracy(m): 33.299999
Eccentricity(-): 5.913425E-003
SQRT(A) (m1/2): 5.153628E+003
Mean Motion Cor(r/s): 4.710911E-009
Mean Anomaly(r): 6.033204E-001
Argument of Perigee(r): 1.418009E+000
Right Ascension(r): 3.520111E-002
Inclination Angle(r): 9.434418E-001
Rate of Right Asc(r/s): -8.210699E-009
Rate of Inc Angle(r/s): 4.503759E-010
Lat Cor, Sine(r): 1.212582E-005
Lat Cor, Cosine(r): 2.004206E-006
Inc Cor, Sine(r): -1.490116E-008
Inc Cor, Cosine(r): -9.872019E-008
Radius Cor, Sine(m): 38.375000
Radius Cor, Cosine(m): 132.937500
Issue of Data : 184
```

Ephemeris Record

- 0x10 (dle is first byte)
- 0x2A (ephemeris record identifier)
- 0x74 (size of data)
- eph_type (see description below)
- one byte chksum (the addition of bytes between the delimiters should equal 0)
- 0x10 (dle)
- 0x03 (etx)

```
typedef struct /* ephemeris record */
{
    char svid; /* Satellite number (0 - 31) */
    int wn; /* week number (weeks) */
    float toc; /* reference time of clock parameters (s) */
    float toe; /* reference time of ephemeris parameters (s) */
    float af0; /* clock correction coefcnt - group delay (s) */
    float af1; /* clock correction coefficient (s/s) */
    float af2; /* clock correction coefficient (s/s/s) */
    float ura; /* user range accuracy (m) */
    double e; /* eccentricity (-) */
    double sqrta; /* square root of semi-major axis (a) (m**1/2) */
    double dn; /* mean motion correction (r/s) */
    double m0; /* mean anomaly at reference time (r) */
    double w; /* argument of perigee (r) */
    double omg0; /* right ascension (r) */
    double i0; /* inclination angle at reference time (r) */
    float odot; /* rate of right ascension (r/s) */
    float idot; /* rate of inclination angle (r/s) */
    float cus; /* argument of latitude correction, sine (r) */
    float cuc; /* argument of latitude correction, cosine (r) */
    float cis; /* inclination correction, sine (r) */
    float cic; /* inclination correction, cosine (r) */
    float crs; /* radius correction, sine (m) */
    float crc; /* radius correction, cosine (m) */
    byte iod; /* issue of data */
} eph_type;
```

To initiate an ephemeris download for all tracked satellites send the following bytes in sequence:

0x10, 0x0D, 0x04, 0x02, 0x0C, 0x0, 0x0, 0xE1, 0x10, 0x03

GPS25PM.DAT

Example data file entry:

```

TIM time_of_week week_number
RCV svid snr (T)rack/(C)ycle_slip phase pseudo_range cycles
PVT time lat lon alt lat_vel lon_vel alt_vel epe eph epv
TIM 235537.99855650 794
RCV 18 50 T 120.2 19964528.44 2068193
RCV 29 50 T 133.2 20364313.25 1950557
RCV 28 45 T 176.5 21135153.13 2069992
RCV 19 47 T 145.2 21190271.83 2182643
RCV 31 45 T 75.8 21240354.20 2216421
RCV 22 42 T 195.1 22849183.41 1855826
RCV 27 36 T 155.2 24234175.55 2230462
RCV 14 39 T 202.3 25147694.34 1845263
PVT 235537.99999842 38.9499588 94.7463684 211.7 -0.19 -0.31 0.13 28 16 23
TIM 235538.99853500 794
RCV 18 50 T 38.8 19958107.10 2101947
RCV 29 50 T 132.4 20358247.54 1982431
RCV 28 45 T 189.5 21128713.01 2103829
RCV 19 47 T 284.6 21183470.16 2218374
RCV 31 45 T 19.0 21233441.89 2252746
RCV 22 42 T 263.0 22843381.08 1886300
RCV 27 36 T 311.7 24227194.88 2267146
RCV 14 39 T 308.3 25141899.86 1875708
PVT 235538.99999827 38.9499550 94.7463684 212.6 -0.19 -0.30 0.14 28 16 23
TIM 235539.99851349 794
RCV 18 50 T 76.6 19951681.26 2135704
RCV 29 50 T 284.4 20352180.11 2014308
RCV 28 45 T 320.8 21122272.68 2137669
RCV 19 47 T 8.3 21176671.33 2254110
RCV 31 45 T 170.2 21226528.82 2289074
RCV 22 42 T 315.9 22837584.50 1916778
RCV 27 36 T 132.4 24220207.85 2303835
RCV 14 39 T 127.4 25136106.23 1906158
PVT 235539.99999812 38.9499512 94.7463684 213.5 -0.19 -0.30 0.13 28 16 23
TIM 235540.99849199 794
RCV 18 50 T 174.9 19945258.21 2169465
RCV 29 50 T 177.7 20346113.87 2046190
RCV 28 45 T 159.6 21115834.07 2171514
RCV 19 47 T 324.7 21169868.61 2289849
RCV 31 45 T 111.8 21219615.05 2325407
RCV 22 42 T 261.7 22831782.87 1947261
RCV 27 36 T 259.1 24213226.41 2340528
RCV 14 39 T 318.7 25130310.86 1936612
PVT 235540.99999797 38.9499474 94.7463760 214.4 -0.19 -0.30 0.14 28 16 23
TIM 235541.99847244 794
RCV 18 50 T 325.5 19938831.69 2203229
RCV 29 50 T 152.1 20340045.44 2078075
RCV 28 45 T 52.4 21109392.21 2205362
RCV 19 47 T 125.3 21163068.15 2325593
RCV 31 45 T 159.4 21212700.30 2361743
RCV 22 43 T 117.1 22825981.54 1977748
RCV 27 36 T 352.1 24206248.88 2377225
RCV 14 39 T 141.3 25124515.72 1967071
PVT 235541.99999977 38.9499474 94.7463760 215.4 -0.19 -0.30 0.13 28 16 23

```

®

GARMIN Corporation
1200 East 151st Street
Olathe, KS 66062
(913)397-8200
(913)397-8282 FAX

190-00148-00 Rev. D